

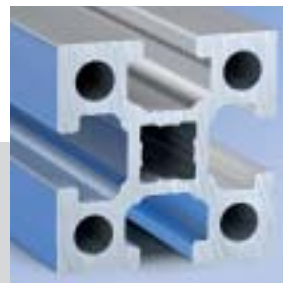

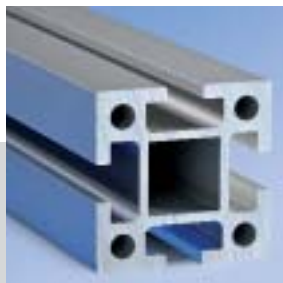

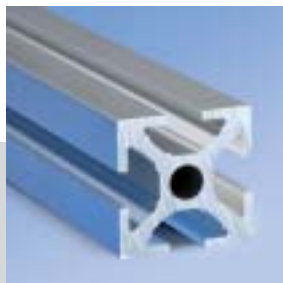

Dati tecnici

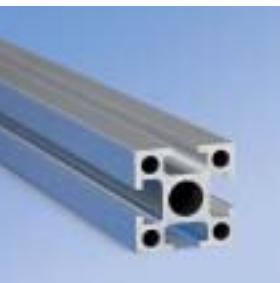

Contenuti Dati tecnici

	Standard, Norme e Calcoli	240
	Determinare la Deformazione Serie 25	244
	Determinare la Deformazione Serie 40	246
	Determinare la Deformazione Serie 50	248
	Determinare la Deformazione Serie 60	250
	Dati tecnici	252

Standard, Norme e Calcoli

Norme e standard

I Profili mk sono in alluminio estruso e sono generalmente disponibili in lunghezze standard di 5100 mm. Tutti i Profili sono disponibile con taglio a misura. Lunghezze più ampie potrebbero essere disponibili su richiesta. Tutti i Profili strutturali sono trattati chimicamente con E6, attraverso il quale vengono rimosse asperità residue.

Come trattamento di superficie, i Profili sono anodizzati con all'incirca 10 µm di tintura c0 (naturale). Tale finitura di superficie è alcalina e resistente all'acido (alcalini fino a PH 9.5 e acidi fino a PH 4). Le tabelle seguenti indicano le deviazioni dimensionali consentite dallo standard con i massimi valori indicati.

Leghe dei Profili mk

in conformità a DIN EN 755 e DIN EN 12020

mk utilizza principalmente due leghe per tutte le serie di Profili: AlMgSi 0.5 F25 per le Serie 25 e 40, AlMgSi 0.7 F28, che ha una resistenza superiore del 7%, per le Serie 50 e 60.

Materiale in conformità a DIN EN 573-3

EN AW 6063 T66
AlMg0.7Si

EN AW 6005A T6
AlSiMg(A)

Materiale in conformità a DIN 1725-1
Numero del materiale

AlMgSi 0,5 F25
3.3206.72

AlMgSi 0.7 F27
3.3210.71

Densità	ρ	g/cm ³	2,7	2,7
Modulo elastico	E	N/mm ²	70.000	70.000
Resistenza alla tensione	Rm	N/mm ²	245	255
Resistenza allo snervamento (0.2%-limite elastico)	Rp0.2	N/mm ²	200	215
Riduzione dell'area	A5	%	8	8
Durezza Brinell	HB		80	85
Coefficiente di espansione termica (fino a 20°C/a 293°K)	α_l	1/K	21.8*10 ⁻⁶	21.8*10 ⁻⁶
(20°-100°C/293°-373°K)			23.2*10 ⁻⁶	23.2*10 ⁻⁶
Conduttività termica	λ	W/(m*K)	200-220	180-220
Conduttività elettrica (20°C/293°K)	κ	m/(Ω *mm ²)	28-34	26-32

Quadratura delle sezioni intersecate

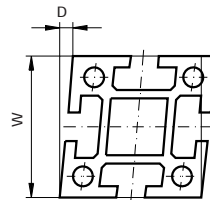

Larghezza W Raggio		Deviazione dal quadrato (mm) D	
oltre	a		
-	40	0.20	
40	60	0.30	
60	90	0.40	
90	120	0.45	
120	150	0.55	
150	180	0.65	
180	210	0.70	

Norme e standard

Rettilineità degli estrusi

La deviazione h_1 da una lunghezza data non dovrebbe eccedere i valori della tabella. Inoltre, il massimo scostamento è 0,3 mm ogni 300 mm lineari. Tutti i valori sono in mm.

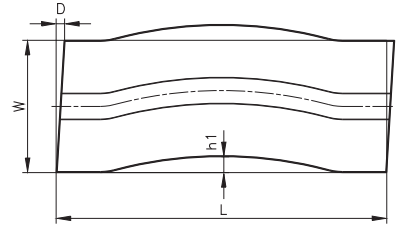

Lunghezza L	a 1000	a 2000	a 3000	a 4000	a 5000	a 6000	oltre 6000
Tolleranza h_1	0.7	1.3	1.8	2.2	2.6	3.0	3.5

Tolleranze per Profili tagliati a misura

Lunghezza L	a 500	a 1000	a 2000	a 6000
Tolleranza	± 0.5	± 0.8	± 1.2	± 2.0
Larghezza W	a 50	a 100	a 200	a 300
Tolleranza angolo D	0.2 mm	0.4 mm	0.8 mm	1.2 mm

Nel caso la tolleranze per le lunghezze sopra descritte non fosse sufficienti, è possibile migliorare l'accuratezza fresando il profilo.

Torsione

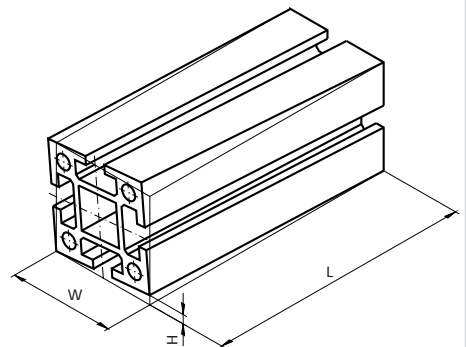

Larghezza W

Torsione consentita H per Lunghezza L

oltre	a	Torsione consentita H per Lunghezza L						per quota
		a 1000	oltre 1000 a 2000	oltre 2000 a 3000	oltre 3000 a 4000	oltre 4000 a 5000	oltre 5000 a 6000	
-	25	1.0	1.5	1.5	2.0	2.0	2.0	
25	50	1.0	1.2	1.5	1.8	2.0	2.0	
50	75	1.0	1.2	1.2	1.5	2.0	2.0	
75	100	1.0	1.2	1.5	2.0	2.2	2.5	
100	125	1.0	1.5	1.8	2.2	2.5	3.0	
125	150	1.2	1.5	1.8	2.2	2.5	3.0	
150	200	1.5	1.8	2.2	2.6	3.0	3.5	
200	300	1.8	2.5	3.0	3.5	4.0	4.5	

Standard, Norme e Calcoli

Deformazione relativa dei Profili base

Carico centrato
Sforzo massimo:

$$M_{bmax} = \frac{F \cdot L}{4} \quad \sigma_b = \frac{M_{bmax}}{W_{x,y}} \quad S = \frac{R_{p0.2}}{\sigma_b}$$

Deformazione massima

$$f = \frac{F \cdot L^3}{48 \cdot E \cdot I_{x,y}}$$

$R_{p0.2} =$
195 N/mm²
(AlMgSi 0,5 F25)

225 N/mm²
(AlMgSi 0,7 F28)

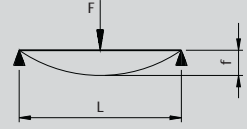

Carico uniforme
Sforzo massimo:

$$M_{bmax} = \frac{q \cdot L^2}{8} \quad \sigma_b = \frac{M_{bmax}}{W_{x,y}} \quad S = \frac{R_{p0.2}}{\sigma_b}$$

Deformazione massima

$$f = \frac{5}{384} \cdot \frac{q \cdot L^4}{E \cdot I_{x,y}}$$

$R_{p0.2} =$
195 N/mm²
(AlMgSi 0,5 F25)

225 N/mm²
(AlMgSi 0,7 F28)

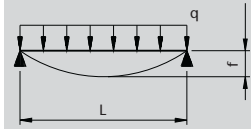

Paragone deformazione di Profili base – Serie 25, 40, 50 e 60

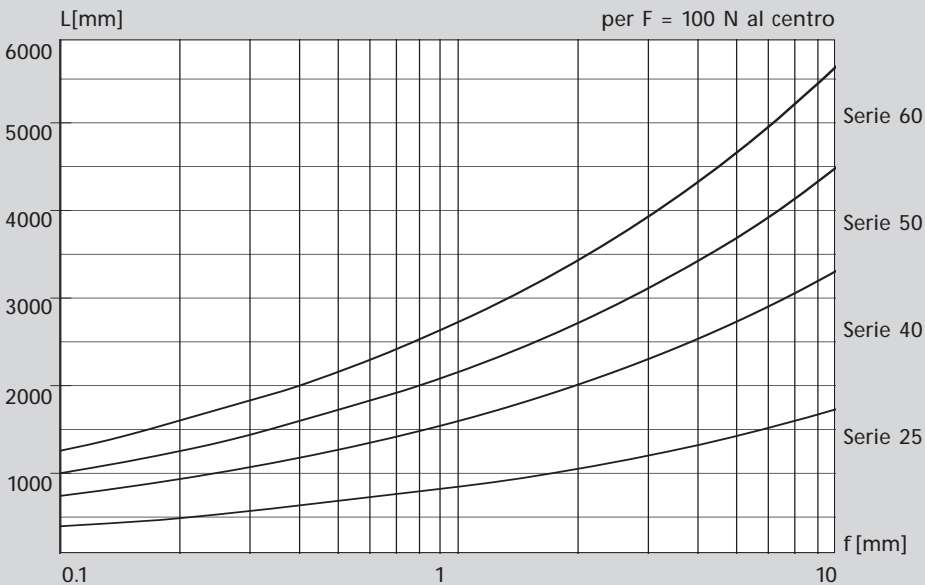

Determinare la Deformazione dei Profili di sistema

La Deformazione dei Profili strutturali mk può essere verificata matematicamente così come con l'uso degli schemi logaritmici seguenti. L'utilizzo dei grafici rappresenta il sistema più veloce per determinare la deformazione. Questo metodo può anche suggerire, dato un Profilo, la deformazione consentita in una particolare situazione di lunghezza o carico. L'utilizzo dell'equazione illustrata è consigliato per determinare l'esatta deformazione.

Gli esempi qui illustrati sono limitati a Profili supportati a entrambe le estremità con

- un carico centrato
- un carico distribuito uniformemente

Dato che il peso della trave stessa può essere considerato un peso distribuito uniformemente, la deformazione da questo provocato può essere ripresa dal grafico "Deformazione data da un carico distribuito uniformemente", o calcolata come illustrato nell'equazione di esempio.

Per determinare la deformazione totale di Profili sovrapposti, deve essere aggiunta la deformazione delle travi individuali (ricorda di includere sia il carico applicato che il peso della trave).

Esamina la seguente applicazione:

La struttura di un macchinario è costruita con l'utilizzo di Profili mk 2025.02, orientati orizzontalmente, come le travi alla sommità.

- Questa struttura è lunga 1585 mm su un lato
- Una superficie piatta è posta sopra queste travi, la quale esercita una forza di 237 N/m (carico distribuito) su questo Profilo.

- Parte dell'attrezzatura è posta sulla superficie piatta, la quale esercita una forza aggiuntiva di 750 N (carico concentrato) sulla trave.

Tale esempio è illustrato nei calcoli a destra.

Attenzione!

Gli esempi illustrati sono validi solo in relazione alla lunghezza delle travi per deformazioni relativamente piccole!

Esempio

Calcolo della deformazione con l'utilizzo del carico concentrato e del peso della trave

Carico: $F_{\text{Conc.}} = 250 \text{ N}$
 $q_{\text{Distr.}} = 237 \text{ N/m}$
 $L = 1585 \text{ mm}$

Profilo: mk 2025.02 (25 x 50 – verticale)

Utilizzando: $I_x = 12.19 \text{ cm}^4 \hat{=} 121900 \text{ mm}^4$
 $q_{\text{Trave}} = 1.35 \text{ kg/m} \hat{=} 13.2 \text{ N/m}$
 $E = 70000 \text{ N/m}^2$ (E-Modulo allum.)

Deformazione causata dal carico

- usando il grafico a pagina 244-250

$$f_{\text{Conc.}} = 2.4 \text{ mm}$$

- utilizzando la formula

$$f_{\text{Conc.}} = \frac{F_{\text{Conc.}} \cdot L^3}{48 \cdot E \cdot I_x} = \frac{250 \text{ N} \cdot 1585^3 \text{ mm}^3}{48 \cdot 70000 \text{ N/mm}^2 \cdot 121900 \text{ mm}^4}$$

$$f_{\text{Conc.}} = 2.43 \text{ mm}$$

Deformazione causata dal carico distribuito

- utilizzando il grafico a pagina 245-251, con $q = q_{\text{Distr.}} + q_{\text{Trave}} = 250 \text{ N/m}$

$$f_{\text{Distr.}} = 2.4 \text{ mm}$$

- utilizzando la formula

$$f_{\text{Distr.}} = \frac{5}{384} \cdot \frac{q \cdot L^4}{E \cdot I_x} = \frac{5}{384} \cdot \frac{0.25 \text{ N/mm} \cdot 1585^4 \text{ mm}^4}{70000 \text{ N/mm}^2 \cdot 121900 \text{ mm}^4}$$

$$f_{\text{Distr.}} = 2.4 \text{ mm}$$

Deformazione totale

$$f_{\text{Totale}} = f_{\text{Conc.}} + f_{\text{Distr.}} = 2.4 \text{ mm} + 2.4 \text{ mm}$$

$$f_{\text{Totale}} = 4.8 \text{ mm}$$

Attenzione!

Assicurarsi del corretto uso delle unità.

Per essere sicuri, fai un confronto tra i calcoli e gli esempi illustrati sotto.

Determinare la Deformazione

Sistema 2000 serie 25

Deformazione da carico centrato Serie 25



Esempio:

Profilo mk 2025.02 (alto)

$I = 12.19 \text{ cm}^4$

$F = 250 \text{ N}$

$L = 1585 \text{ mm}$

$f = 2.4 \text{ mm}$

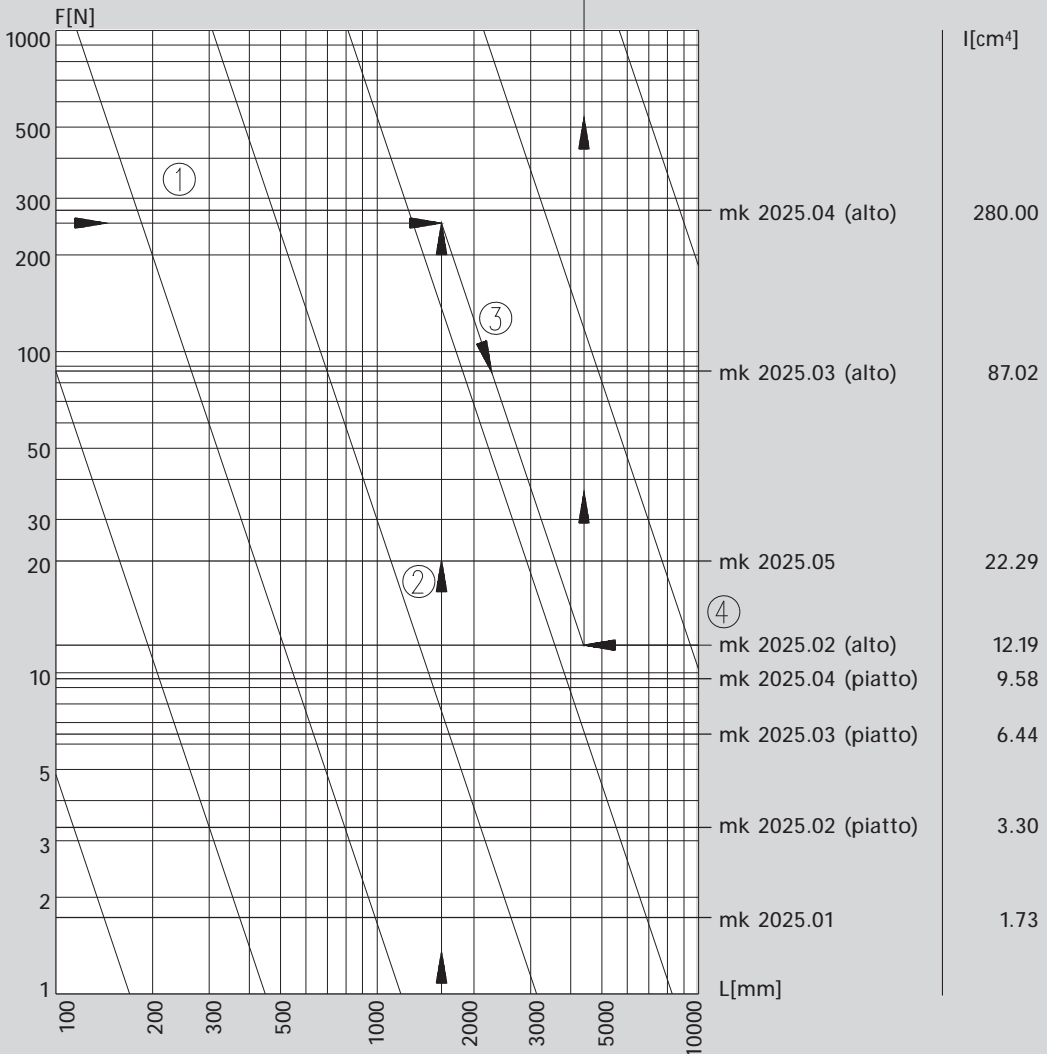
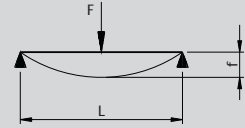

Deformazione da carico distribuito Serie 25



Esempio:

Profilo mk 2025.02 (alto)

$I = 12.19 \text{ cm}^4$

$F = 250 \text{ N}$

$L = 1585 \text{ mm}$

$f = 2.4 \text{ mm}$

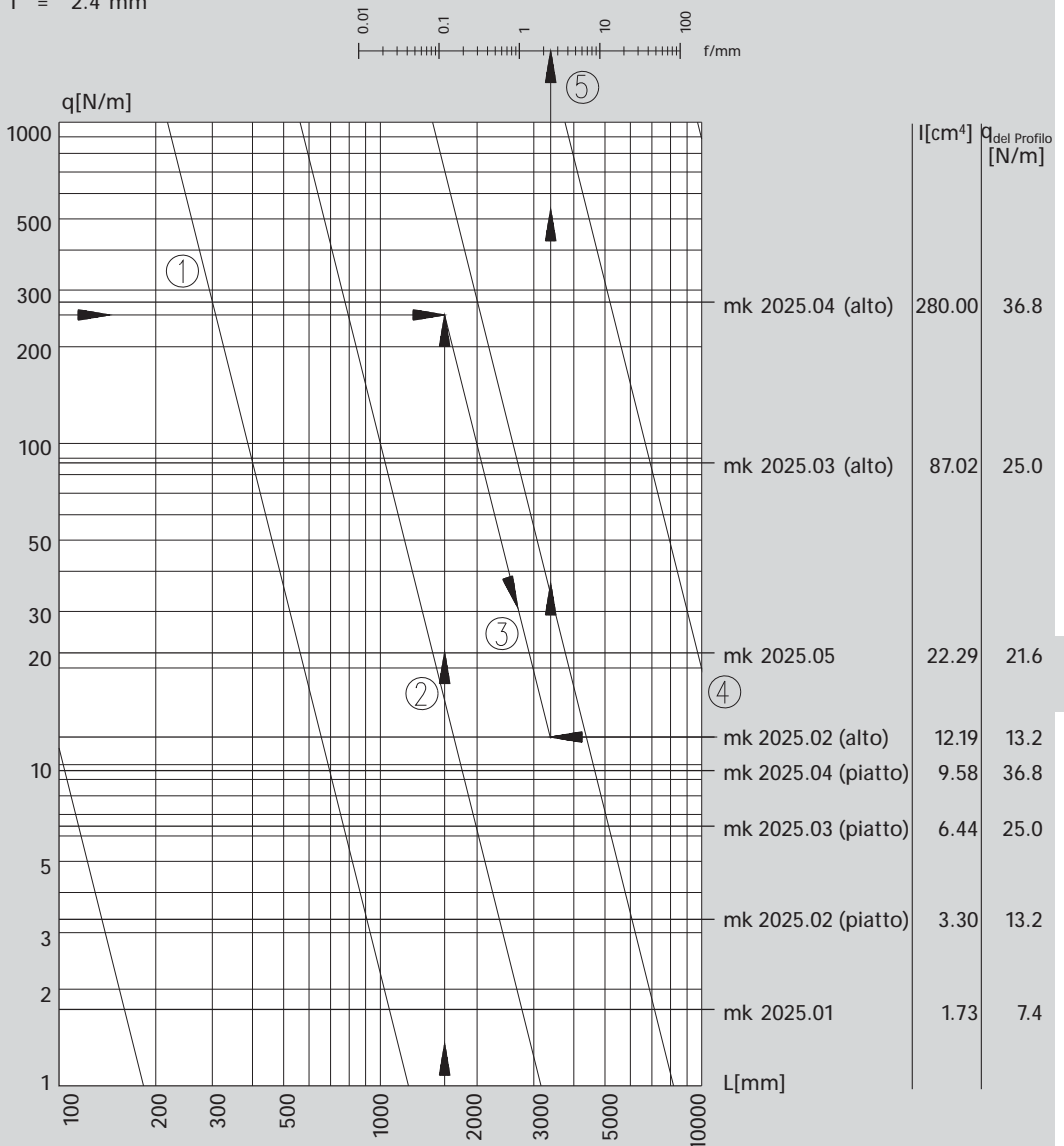
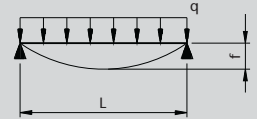

Determinare la Deformazione

Sistema 2000 serie 40

Deformazione da carico centrato
Serie 40

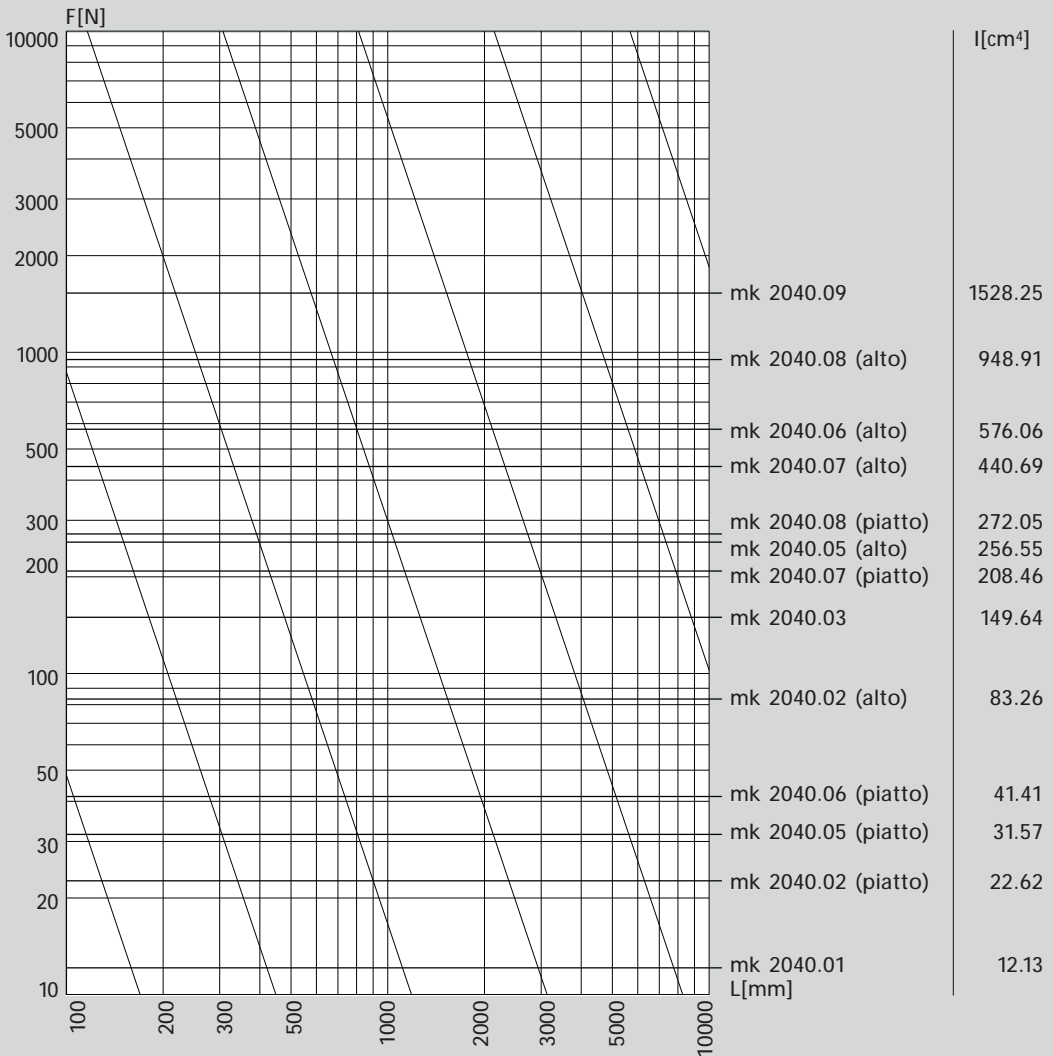
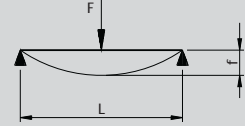

Deformazione da carico distribuito
 Serie 40

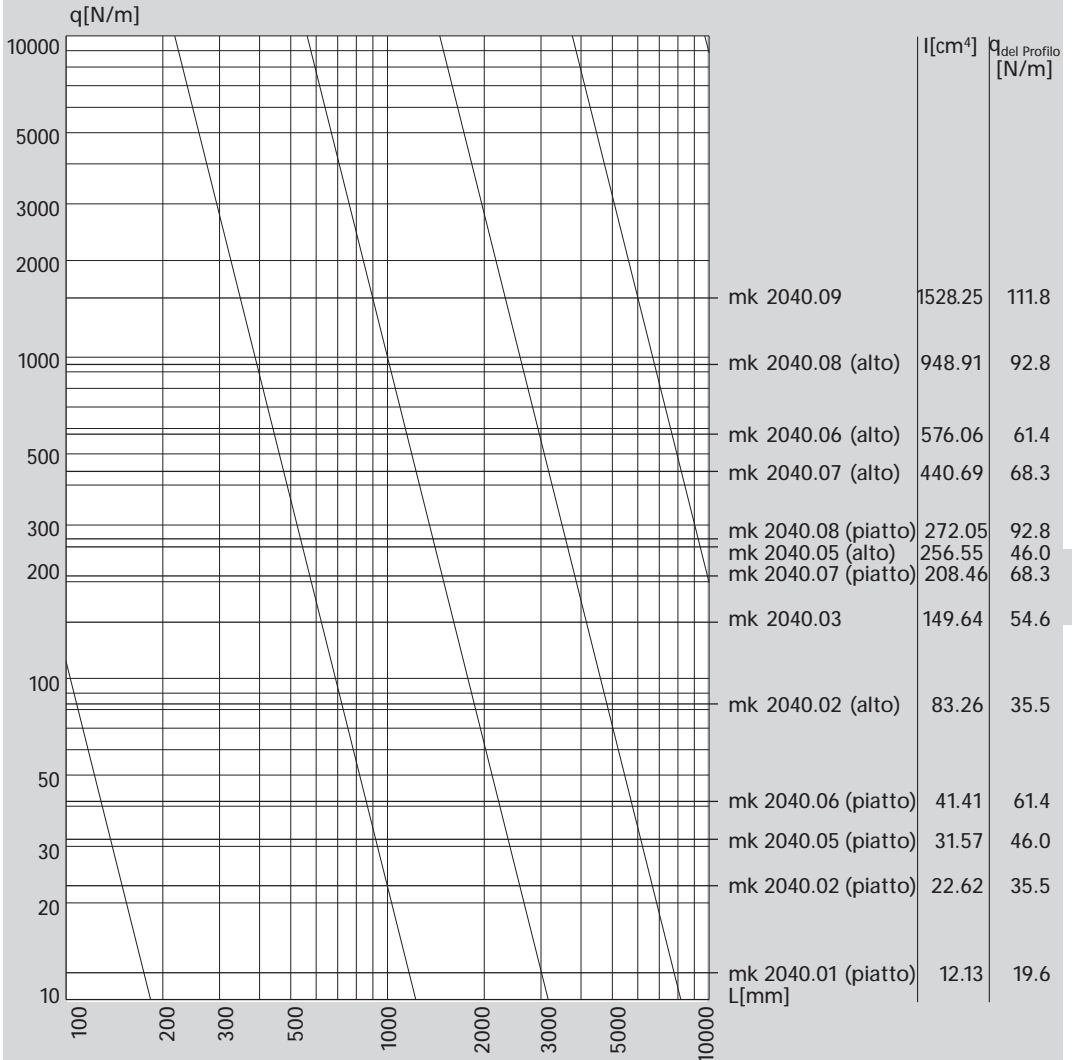
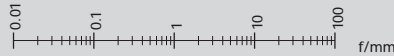
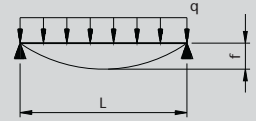

Determinare la Deformazione

Sistema 2000 serie 50

Deformazione da carico centrato
Serie 50

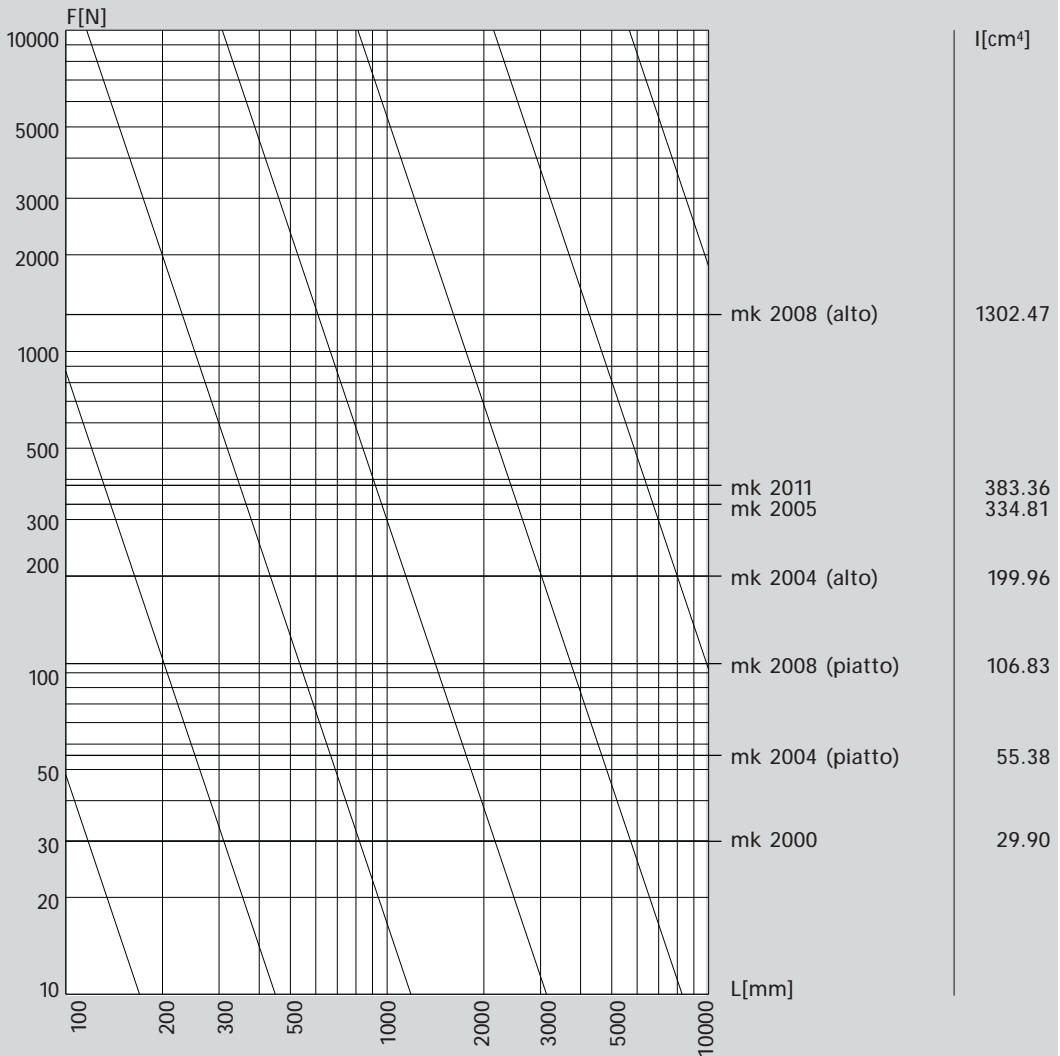
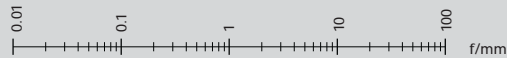
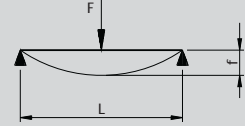

Deformazione da carico distribuito
 Serie 50

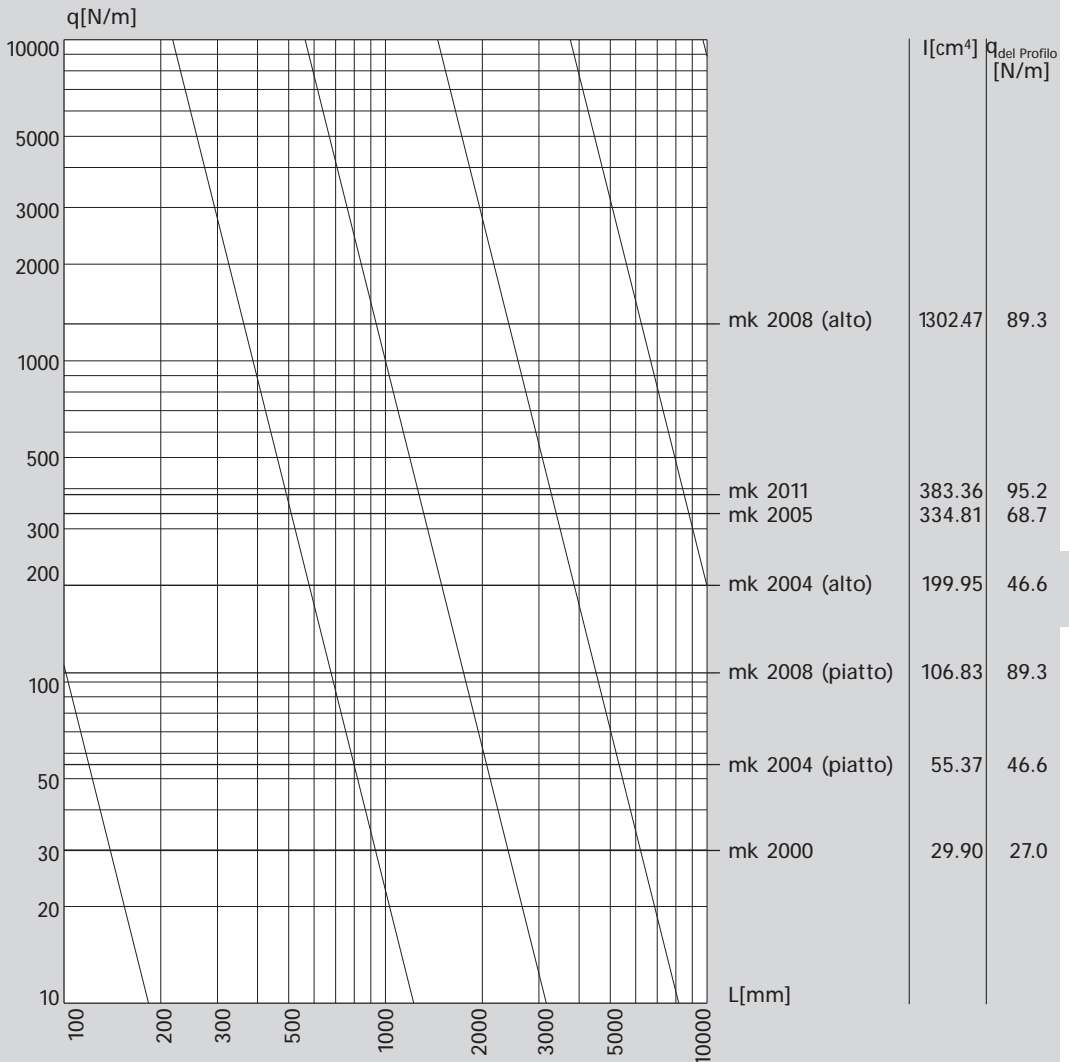
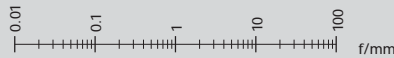
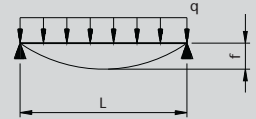

Determinare la Deformazione

Sistema 2000 serie 60

Deformazione da carico centrato
Serie 60

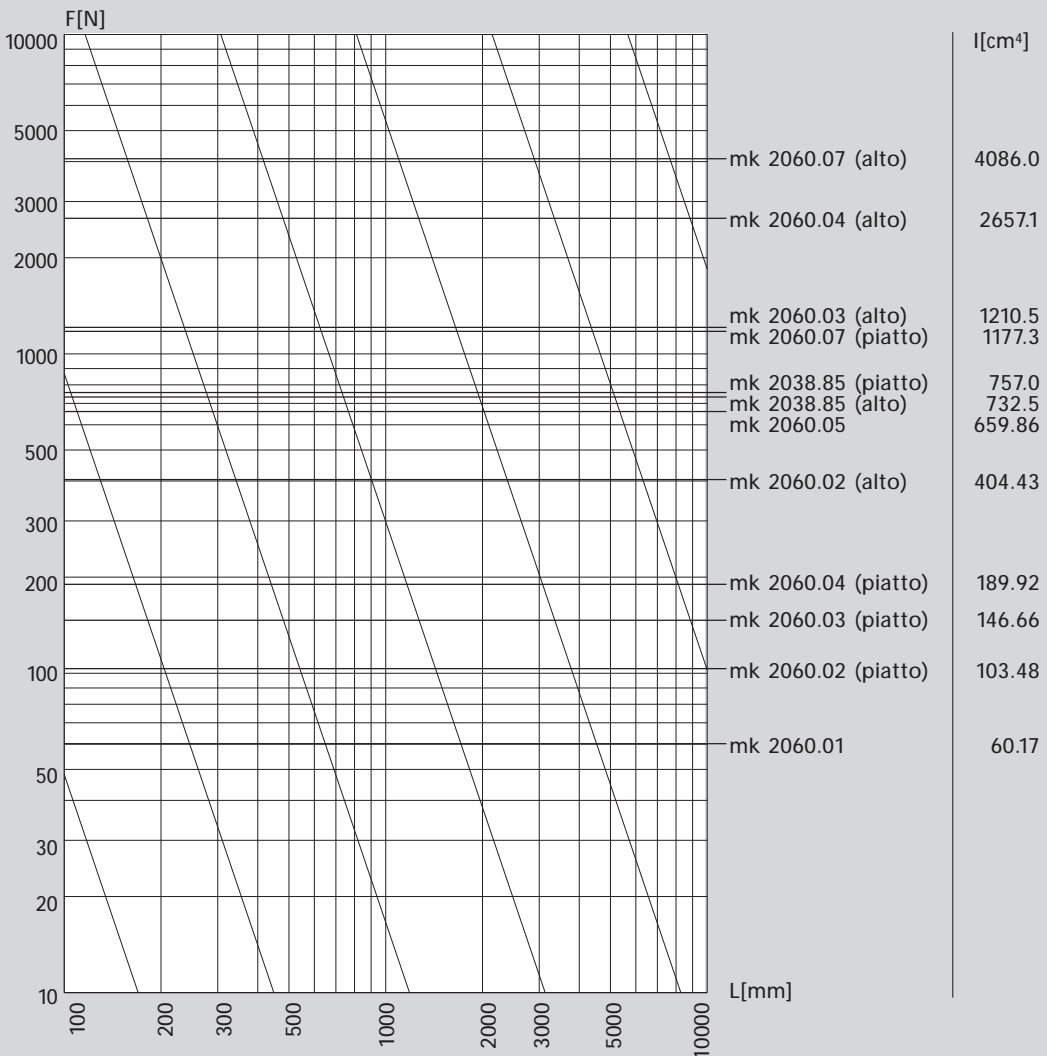
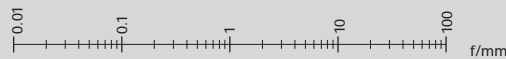
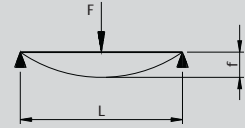
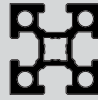



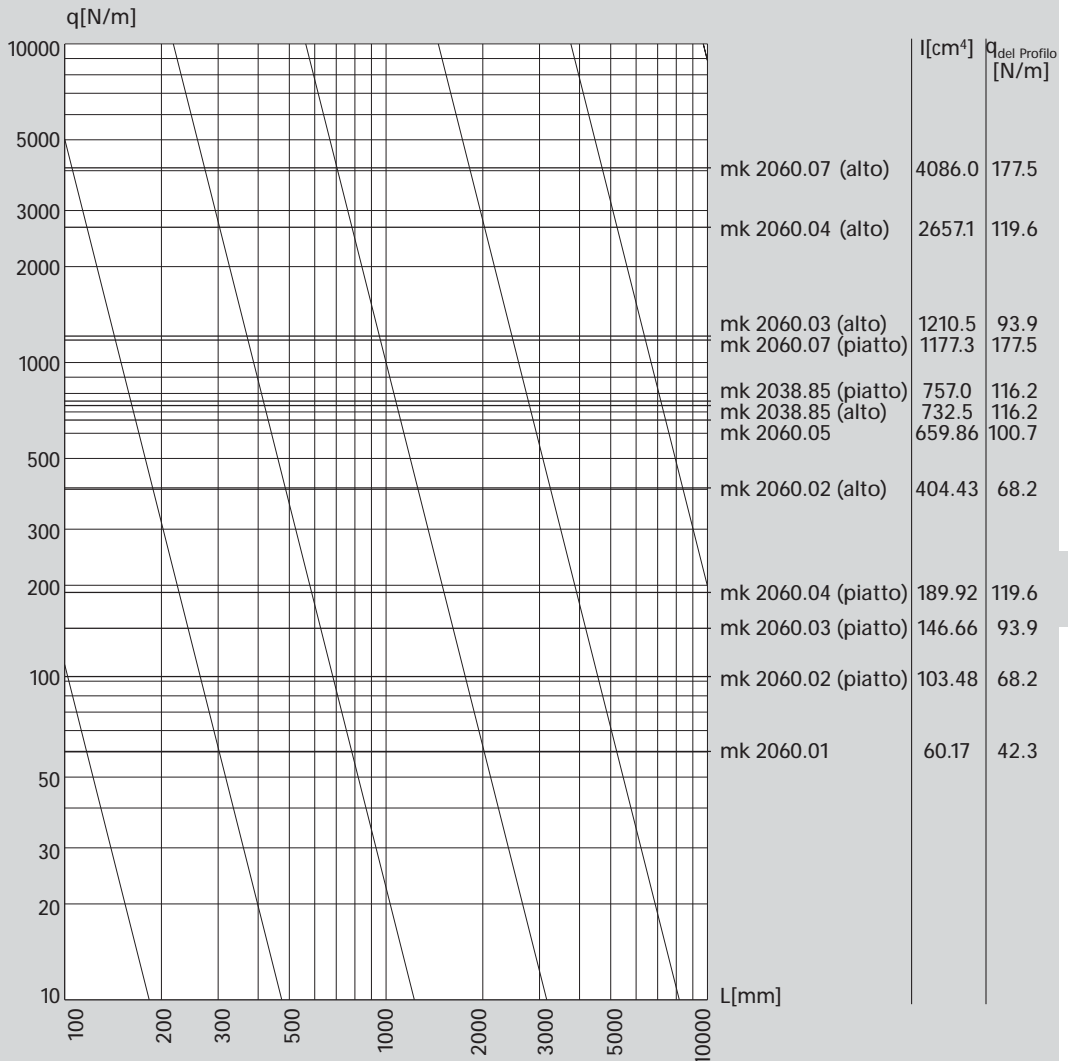
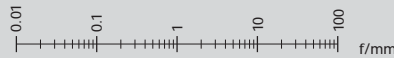
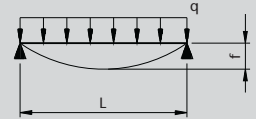





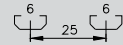

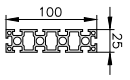
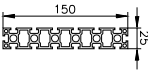









Deformazione da carico distribuito
 Serie 60

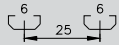
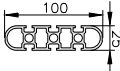

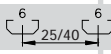
Dati tecnici

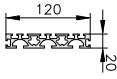
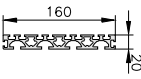
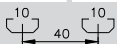



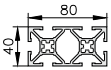
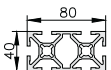



Profili strutturali

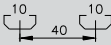
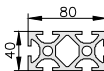
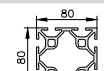
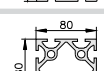
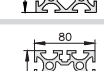
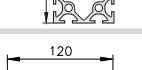
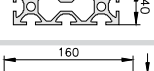









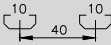



Profilo	Simbolo Profilo	Area di superficie	Massa per lunghezza	Momento di inerzia		Modulo sezione		Pagina
		A [mm ²]	m [kg/m]	I _x [cm ⁴]	I _y [cm ⁴]	W _x [cm ³]	W _y [cm ³]	
<i>Profilo Serie 25</i> 								
mk 2025.01		279	0.75	1.73	1.73	1.38	1.38	31
mk 2025.02		501	1.35	12.19	3.3	4.87	2.64	31
mk 2025.03		945	2.55	87.02	6.44	17.4	5.15	31
mk 2025.04		1390	3.75	280	9.58	37.33	7.66	31
mk 2025.05		816	2.21	22.3	22.3	8.9	8.9	31
mk 2025.31		284	0.77	1.73	1.62	1.42	1.29	32
mk 2025.35		275	0.75	1.71	1.68	1.38	1.34	32
mk 2025.38		290	0.79	1.52	1.48	1.27	1.25	32
mk 2025.37		267	0.73	1.32	1.28	1.14	1.12	33
mk 2025.32		475	1.29	3.22	12.03	2.6	4.81	33
mk 2025.36		462	1.25	3.12	11.88	2.58	4.81	33
mk 2025.39		407	1.1	2.05	9.44	1.81	3.77	33
mk 2025.25		482	1.3	9.99	9.99	3.76	3.76	33

Profilo	Simbolo Profilo	Area di superficie	Massa per lunghezza	Momento di inerzia		Modulo sezione		Pagina
		A [mm ²]	m [kg/m]	I _x [cm ⁴]	I _y [cm ⁴]	W _x [cm ³]	W _y [cm ³]	
<i>Profilo Serie 25</i> 								
mk 2025.22		837	2.26	64.26	5.84	12.95	4.67	34
mk 2025.20		783	2.12	15.51	15.52	6.2	5.45	34
mk 2025.21		1100	2.98	43.62	43.62	12.46	12.46	34
<i>Profilo di adattamento Serie 25/40</i> 								
mk 2025.41		377	1.02	6.2	1.49	3.1	1.39	35
mk 2025.42		717	1.94	42.51	2.97	10.63	2.88	35
mk 2025.43		1060	2.86	136.21	4.44	22.7	4.37	35
mk 2025.44		1400	3.77	314.51	5.9	39.29	5.86	35
<i>Profilo Serie 40</i> 								
mk 2040.31		561	1.50	9.69	9.69	4.84	4.84	37
mk 2040.40		606	1.64	10.52	10.52	5.26	5.26	37
mk 2040.01		742	2.00	12.13	12.13	6.06	6.06	37
mk 2040.52		988	2.67	64.10	17.50	16.00	8.76	37
mk 2040.41		1160	2.85	68.89	18.67	17.22	9.33	38

Dati tecnici

Profili strutturali









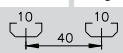
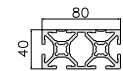
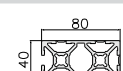
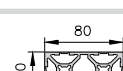
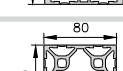
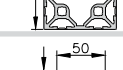
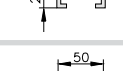
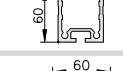
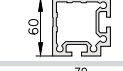
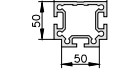
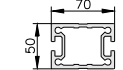
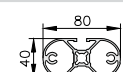
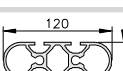

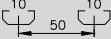
Profilo	Simbolo Profilo	Area di superficie	Massa per lunghezza	Momento di inerzia		Modulo sezione		Pagina
		A [mm ²]	m [kg/m]	I _x [cm ⁴]	I _y [cm ⁴]	W _x [cm ³]	W _y [cm ³]	
<i>Profilo Serie 40</i> 								
mk 2040.02		1340	3.62	83.26	22.62	20.84	11.31	38
mk 2040.45		1760	4.75	127.89	127.89	31.94	31.94	38
mk 2040.03		2060	5.57	149.64	149.64	37.41	37.41	38
mk 2040.73		2110	5.72	150.00	150.00	37.10	37.40	38
mk 2040.05		1740	4.69	256.55	31.57	43.75	15.78	38
mk 2040.06		2320	6.26	576.06	41.41	72.01	20.70	38
mk 2040.07		2580	6.96	440.69	208.46	73.44	52.11	39
mk 2040.08		3500	9.46	948.91	272.05	118.62	68.01	39
mk 2040.10		3060	8.26	585.21	585.21	97.51	97.51	39
mk 2040.09		4220	11.40	1528.25	1528.25	191.03	191.03	39
mk 2040.21		685	1.84	11.00	10.21	5.42	5.10	40
mk 2040.11		696	1.88	11.13	11.13	5.50	5.50	40
mk 2040.14		604	1.62	8.30	8.30	4.75	4.75	40

Profilo	Simbolo Profilo	Area di superficie	Massa per lunghezza	Momento di inerzia		Modulo sezione		Pagina
		A [mm ²]	m [kg/m]	I _x [cm ⁴]	I _y [cm ⁴]	W _x [cm ³]	W _y [cm ³]	
<i>Profilo Serie 40</i> 								
mk 2040.15		561	1.51	7.85	7.85	4.54	4.54	40
mk 2040.22		1270	3.43	21.53	75.54	10.72	18.89	41
mk 2040.12		1270	3.43	21.39	77.91	10.86	19.86	41
mk 2040.24		832	2.25	16.60	66.07	8.30	16.34	41
mk 2040.46		2020	5.44	145.08	145.56	35.63	36.38	41
mk 2040.13		1970	5.32	141.92	141.92	36.05	36.05	41
mk 2040.04		1340	3.61	71.82	71.82	18.80	18.80	41
mk 2040.16		445	1.25	5.28	6.22	2.87	3.11	42
mk 2040.92		623	1.68	11.00	10.56	5.40	5.28	43
mk 2040.93		634	1.72	11.00	11.00	5.40	5.40	42
mk 2040.94		634	1.72	11.40	10.50	5.73	5.28	42
mk 2040.95		647	1.75	11.00	11.40	5.41	5.74	43
mk 2040.96		659	1,78	11,48	11,48	5,74	5,74	43

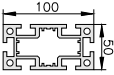
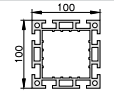
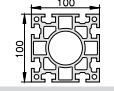
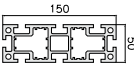
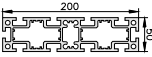
Dati tecnici





Profili strutturali

Profilo	Simbolo Profilo	Area di superficie	Massa per lunghezza	Momento di inerzia		Modulo sezione		Pagina
		A [mm ²]	m [kg/m]	Ix [cm ⁴]	Iy [cm ⁴]	Wx [cm ³]	Wy [cm ³]	
<i>Profilo Serie 40</i> 								
mk 2040.100		1090	2.94	19.68	70.83	9.63	17.71	43
mk 2040.101		1100	2.97	19.69	72.70	9.64	17.98	43
mk 2040.104		1138	3,07	20,60	75,50	18,80	10,30	43
mk 2040.109		1860	5,04	138,00	138,00	34,50	34,50	43
mk 2040.37		426	1.17	2.74	14.65	1.09	9.73	47
mk 2040.38		933	2.52	43.13	32.45	13.60	12.98	47
mk 2040.39		1110	3.00	49.87	49.87	16.31	16.31	47
mk 2040.74		1300	3.50	74.32	56.44	21.23	18.66	47
mk 2040.75		1120	3.01	68.36	38.58	27.35	11.02	47
mk 2040.23		785	2.12	42.60	12.00	10.70	5.90	48
mk 2040.34		1310	3.56	139.67	24.15	23.53	12.08	48
mk 2040.30		1620	4.36	242.23	67.65	40.20	19.84	48

Profilo	Simbolo Profilo	Area di superficie	Massa per lunghezza	Momento di inerzia		Modulo sezione		Pagina
		A [mm ²]	m [kg/m]	I _x [cm ⁴]	I _y [cm ⁴]	W _x [cm ³]	W _y [cm ³]	
<i>Profilo Serie 50</i> 								
mk 2001		542	1.49	14.26	2.67	5.70	1.82	55
mk 2000		1080	2.85	29.90	29.90	11.96	11.96	55
mk 2002		693	1.75	19.56	19.56	7.83	7.83	55
mk 2004		1810	4.87	199.96	55.38	39.99	22.15	55
mk 2005		2650	7.00	334.81	334.81	66.96	66.96	56
mk 2011		3670	9.70	383.36	383.36	76.67	76.67	56
mk 2006		2600	7.00	597.00	80.50	79.70	32.10	56
mk 2008		3370	9.09	1302.47	106.83	130.24	42.73	56
mk 2072		1710	4.62	151.77	151.77	28.75	28.75	56
mk 2003		762	2.00	14.01	14.01	6.49	6.49	56
mk 2017		1120	3.03	30.60	31.30	12.10	12.50	57
mk 2033		554	1.50	5.22	27.72	4.94	9.24	58
mk 2031		1120	2.85	79.17	55.59	23.18	18.53	58

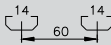
Dati tecnici

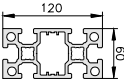
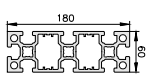
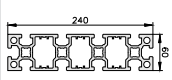
Profili strutturali

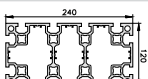
Profilo	Simbolo Profilo	Area di superficie	Massa per lunghezza	Momento di inerzia		Modulo sezione		Pagina
		A [mm ²]	m [kg/m]	I _x [cm ⁴]	I _y [cm ⁴]	W _x [cm ³]	W _y [cm ³]	
<i>Profilo Serie 60</i>								
mk 2060.01		1600	4.31	60.17	60.17	20.05	20.05	61
mk 2060.02		2580	6.95	404.43	103.48	67.34	34.49	61
mk 2060.03		3540	9.57	1210.53	146.66	134.50	48.89	61
mk 2060.04		4520	12.20	2657.18	189.92	221.18	63.28	62
mk 2060.05		3800	10.30	659.86	659.86	109.85	109.85	62
mk 2060.07		6700	18.10	4086.05	1177.39	340.50	169.23	62

Dati tecnici

Tavola di conversione

Lunghezza	[mm]	[cm]	[m]	[in]	[ft]
1 Millimetro [mm]	= 1	0.1	0.001	0.0394	0.0033
1 Centimetro [cm]	= 10	1	0.01	0.3937	0.0328
1 Metro [m]	= 1000	100	1	39.37	3.281
1 Pollice [" / in]	= 25.4	2.54	0.0254	1	0.083
1 Piede [' / ft]	= 304.8	30.48	0.3048	12	1
Area	[mm ²]	[cm ²]	[m ²]	[in ²]	[ft ²]
1 Millimetro quadrato [mm ²]	= 1	0.01		0.0016	
1 Centimetro quadrato [cm ²]	= 100	1	0.0001	0.155	0.0011
1 Metro quadrato [m ²]	=	10000	1	1550	10.76
1 Pollice quadrato [in ²]	= 645.6	6.452	0.0006	1	0.0069
1 Piede quadrato [ft ²]	=	929	0.0929	144	1
Volume	[mm ³]	[cm ³]	[m ³]	[in ³]	[ft ³]
1 Millimetro cubo [mm ³]	= 1		0.001		0.000006
1 Centimetro cubo [cm ³]	= 1000		1		0.061
1 Pollice cubo [cu.in.]	= 163871		16.39		1
Momento d'inerzia	[cm ⁴]	[in ⁴]	[m ⁴]	[ft ⁴]	[in ⁴]
1 Centimetro ⁴ [cm ⁴]	= 1				0.024
1 Pollice ⁴ [in ⁴]	= 41.62				1
Massa	[kg]	[lb]	[g]	[oz]	[lb]
1 Chilogrammo [kg]	= 1				2.205
1 Libbra [lb]	= 0.4536				1
Forza	[N]	[lbf]	[kgf]	[dyn]	[lbf]
1 Newton [N]	= 1				0.2248
1 Pound-Force [lbf]	= 4.448				1
Torsione	[Nm]	[lb-in]	[kgf-cm]	[in-lb]	[lb-in]
1 Newton-Metro [Nm]	= 1				8.851
1 Libbre-forza per pollice [lb-in]	= 0.113				1
Pressione	[bar]	[psi]	[atm]	[mmHg]	[psi]
1 Bar [bar]	= 1				14.5
1 Libbra per pollice quadrato [psi]	= 0.069				1
Potenza	[kW]	[hp]	[CV]	[W]	[hp]
1 Kilowatt [kW]	= 1				1.341
1 Horsepower [hp]	= 0.7457				1